

gunstige Flaechenpressung  
optimale Arbeitsposition

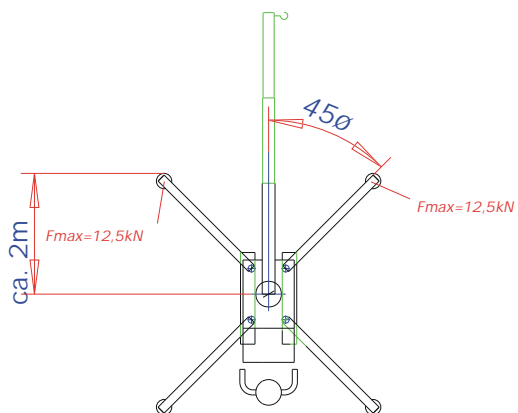

ungenstige Flaechenpressung

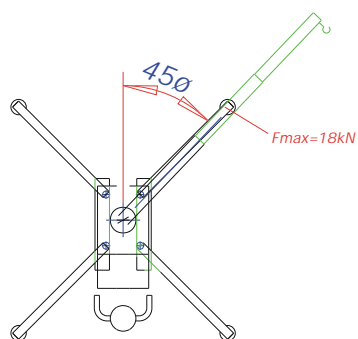

Aktionsradius

